

BMW E81 mit Serienheckschürze/Serial Valance
118d (105 kW) ♦ 120d (130 kW)

Artikel	Endrohre	Durchmesser	Bestellnummer	MSRP
Item	Tip design	Tip dimension	Part number	
ESD / RM	OO	2x Ø 70 mm+	B5341.00702	
ESD / RM	OO OO	4x Ø 70 mm+	B5341.00704	

BMW E81 mit M-Technik-Serienheckschürze/M-Technik Valance
118d (105 kW) ♦ 120d (130 kW)

Artikel	Endrohre	Durchmesser	Bestellnummer	MSRP
Item	Tip design	Tip dimension	Part number	
ESD / RM	OO	2x Ø 70 mm+	B5341.09702	
ESD / RM	OO OO	4x Ø 70 mm+	B5341.09704	

BMW E81
116i (85 kW) ♦118i (105 kW) ♦ 120i (125 kW)

Artikel	Endrohre	Durchmesser	Bestellnummer	MSRP
Item	Tip design	Tip dimension	Part number	
ESD / RM	OO	2x Ø 70 mm+	B5342.00702	
ESD / RM	OO OO	4x Ø 70 mm+	B5342.00704	

BMW E81
130i (195 kW)

Artikel	Endrohre	Durchmesser	Bestellnummer	MSRP
Item	Tip design	Tip dimension	Part number	
ESD / RM	OO	2x Ø 70 mm+	B5343.00702	
ESD / RM	OO OO	4x Ø 70 mm+	B5343.00704	

BMW E87 mit Serienheckschürze/Serial Valance
118d (89 kW/90 kW) ♦ 120d (110 kW/120 kW)

Artikel	Endrohre	Durchmesser	Bestellnummer	MSRP
Item	Tip design	Tip dimension	Part number	
ESD / RM	OO	2x Ø 70 mm+	B5323.00700	\$ 672.10
ESD / RM	OO OO	4x Ø 70 mm+	B5323.02320	\$ 1,376.32

BMW E87 mit M-Technik-Serienheckschürze/M-Technik Valance
118d (89 kW/90 kW) ♦ 120d (110 kW/120 kW)

Artikel	Endrohre	Durchmesser	Bestellnummer	MSRP
Item	Tip design	Tip dimension	Part number	
ESD / RM	OO	2x Ø 70 mm+	B5323.09700	\$ 672.10
ESD / RM	OO OO	4x Ø 70 mm+	B5323.02420	\$ 1,376.32

BMW E87
116i (85 kW) ♦118i (95 kW) ♦ 120i (110 kW)

Artikel	Endrohre	Durchmesser	Bestellnummer	MSRP
Item	Tip design	Tip dimension	Part number	
ESD / RM	OO	2x Ø 70 mm+	B5324.00700	\$ 848.76
ESD / RM	OO OO	4x Ø 70 mm+	B5324.02320	\$ 1,424.50

BMW E87
130i (195 kW)

Artikel	Endrohre	Durchmesser	Bestellnummer	MSRP
Item	Tip design	Tip dimension	Part number	
ESD / RM	OO	2x Ø 70 mm+	B5326.00700	\$ 1,376.32
ESD / RM	OO OO	4x Ø 70 mm+	B5326.02320	\$ 2,096.60

BMW E30
320i (95 kW)

Artikel	Endrohre	Durchmesser	Bestellnummer	MSRP
Item	Tip design	Tip dimension	Part Number	
AR / CP			B5003.00000	\$ 232.57
ESD / RM	OO	2x Ø 70 mm+	B5203.00700	\$ 1,005.12

BMW E30
325i (126 kW)

Artikel	Endrohre	Durchmesser	Bestellnummer	MSRP
Item	Tip design	Tip dimension	Part Number	
AR / CP			B5003.00000	\$ 232.57
ESD / RM	OO	2x Ø 70 mm+	B5204.00700	\$ 1,005.12

BMW E30 M3
2,5l (143 kW)(148 kW)[23 4 E A] ♦ 2,5l (158 kW)[23 4 S 2]

Artikel	Endrohre	Durchmesser	Bestellnummer	MSRP
Item	Tip design	Tip dimension	Part Number	
ESD / RM	OO	2x Ø 70 mm	B5206.00700	\$ 1,037.24

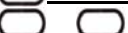

BMW E36
316i (3) (75 kW)

Artikel	Endrohre	Durchmesser	Bestellnummer	MSRP
Item	Tip design	Tip dimension	Part Number	
AR / CP			B5004.00000	\$ 184.39
ESD / RM	OO	2x Ø 70 mm (2)+	B5207.00700	\$ 816.64
ESD / RM	OO	2x Ø 76 mm+	B5207.00760	\$ 848.76
ESD / RM	OO	2x Ø 83 mm+	B5207.00831	\$ 896.94
ESD / RM	OO OO	4x Ø 70*mm+	B5207.02320	\$ 1,448.59
ESD / RM		1x 160x80 mm ^{oo+}	B5207.02250	\$ 896.94
ESD / RM		2x 160x80* mm ^{oo+}	B5207.02260	\$ 1,504.80

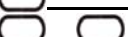

BMW E36
318i (85 kW)

Artikel	Endrohre	Durchmesser	Bestellnummer	MSRP
Item	Tip design	Tip dimension	Part Number	
AR / CP			B5004.00000	\$ 184.39
ESD / RM	OO	2x Ø 70 mm (2)+	B5210.00700	\$ 816.64
ESD / RM	OO	2x Ø 76 mm+	B5210.00760	\$ 848.76
ESD / RM	OO	2x Ø 83 mm+	B5210.00831	\$ 896.94
ESD / RM	OO OO	4x Ø 70*mm+	B5210.02320	\$ 1,448.59
ESD / RM		1x 160x80 mm ^{oo+}	B5210.02250	\$ 896.94
ESD / RM		2x 160x80* mm ^{oo+}	B5210.02260	\$ 1,504.80



BMW E36
318iS (103 kW)

Artikel	Endrohre	Durchmesser	Bestellnummer	MSRP
Item	Tip design	Tip dimension	Part Number	
ESD / RM	OO	2x Ø 70 mm (2)+	B5212.00700	\$ 832.70
ESD / RM	OO	2x Ø 76 mm+	B5212.00760	\$ 864.82
ESD / RM	OO	2x Ø 83 mm+	B5212.00831	\$ 973.00
ESD / RM	OO OO	4x Ø 70*mm+	B5212.02320	\$ 1,464.65
ESD / RM		1x 160x80 mm ^{°°} +	B5212.02250	\$ 973.00
ESD / RM		2x 160x80*mm ^{°°} +	B5212.02260	\$ 1,520.86



BMW E36
320i (110 kW) ♦ 323i (125 kW)

Artikel	Endrohre	Durchmesser	Bestellnummer	MSRP
Item	Tip design	Tip dimension	Part Number	
AR / CP			B5005.00000	\$ 200.45
ESD / RM	OO	2x Ø 70 mm (2)+	B5216.00700	\$ 880.88
ESD / RM	OO	2x Ø 76 mm+	B5216.00760	\$ 973.00
ESD / RM	OO	2x Ø 83 mm+	B5216.00831	\$ 1,021.18
ESD / RM	OO OO	4x Ø 70*mm+	B5216.02320	\$ 1,512.83
ESD / RM		1x 160x80 mm ^{°°} +	B5216.02250	\$ 1,021.18
ESD / RM		2x 160x80*mm ^{°°} +	B5216.02260	\$ 1,569.04

BMW E36
325i (141 kW) ♦ 328i (142 kW)

Artikel	Endrohre	Durchmesser	Bestellnummer	MSRP
Item	Tip design	Tip dimension	Part Number	
AR / CP			B5006.00000	\$ 224.54
ESD / RM	OO	2x Ø 70 mm	B5220.00700	\$ 1,013.15
ESD / RM	OO	2x Ø 76 mm+	B5220.00760	\$ 1,045.27
ESD / RM	OO	2x Ø 83 mm+	B5220.00831	\$ 1,143.45
ESD / RM	OO OO	4x Ø 70*mm+	B5220.02320	\$ 1,585.10
ESD / RM		1x 160x80 mm ^{°°} +	B5220.02250	\$ 1,143.45
ESD / RM		2x 160x80*mm ^{°°} +	B5220.02260	\$ 1,691.31

BMW E36 M3
3,0i (210 kW) ♦ 3,2i (236 kW)

Artikel	Endrohre	Durchmesser	Bestellnummer	MSRP
Item	Tip design	Tip dimension	Part Number	
ESD ■ / RM ■	OO	2x Ø 70 mm	B5223.00700	\$ 1,296.02
ESD ■ / RM ■	OO	2x Ø 76 mm+	B5223.00760	\$ 1,328.14
ESD ■ / RM ■	OO	2x Ø 83 mm+	B5223.00831	\$ 1,376.32
ESD■(11)/RM■(11)	OO OO	4x Ø 70*mm+	B5223.02320	\$ 1,867.97
ESD ■ / RM ■		1x 160x80 mm ^{°°} +	B5223.02250	\$ 1,376.32
ESD■(11)/RM■(11)		2x 160x80* mm ^{°°} +	B5223.02260	\$ 1,984.18

BMW E36 Compact
316i (75 kW) -->12/1998

Artikel	Endrohre	Durchmesser	Bestellnummer	MSRP
Item	Tip design	Tip dimension	Part number	
ESD / RM	OO	2x Ø 70 mm+	B5208.00700	\$ 816.64

BMW E36 Compact
316i (77 kW) 01/1999-->

Artikel	Endrohre	Durchmesser	Bestellnummer	MSRP
Item	Tip design	Tip dimension	Part number	
ESD / RM	OO	2x Ø 70 mm+	B5221.00700	\$ 784.52

BMW E36 Compact
318ti (103 kW)

Artikel	Endrohre	Durchmesser	Bestellnummer	MSRP
Item	Tip design	Tip dimension	Part number	
ESD / RM	OO	2x Ø 70 mm+	B5209.00700	\$ 824.67



BMW E36 Compact
323ti (125 kW) -->12/1999

Artikel	Endrohre	Durchmesser	Bestellnummer	MSRP
Item	Tip design	Tip dimension	Part number	
ESD / RM	OO	2x Ø 70 mm+	B5242.00700	\$ 989.06



BMW E36 Compact
323ti (125 kW) 01/2000-->

Artikel	Endrohre	Durchmesser	Bestellnummer	MSRP
Item	Tip design	Tip dimension	Part number	
ESD / RM	OO	2x Ø 70 mm+	B5309.00700	\$ 989.06

BMW E46
316i (77 kW+85 kW) ♦ 318i/ci (87 kW)[M43] ♦ 320i/ci (110 kW)[M52] ♦ 323i/ci (120 kW+125 kW)
328i/ci (142 kW)

Artikel	Endrohre	Durchmesser	Bestellnummer	MSRP
Item	Tip design	Tip dimension	Part number	
SR(!)(9)/SP(!)(9)			B5007.00000	\$ 240.60
ESD / RM	OO	2x Ø 70 mm	B5246.00700	\$ 896.94
ESD / RM	OO	2x Ø 76 mm+	B5246.00760	\$ 989.06
ESD / RM	OO	2x Ø 83 mm+	B5246.00831	\$ 1,037.24
ESD / RM	OO OO	4x Ø 70*mm+	B5246.02320	\$ 1,528.89
ESD / RM		1x 160x80 mm ^{oo+}	B5246.02250	\$ 1,037.24
ESD / RM		2x 160x80*mm ^{oo+}	B5246.02260	\$ 1,585.10

BMW E46
316i/ci (85 kW)[N40][N42][N45][N46] ♦ 318i/ci (105 kW)[N42][N46]

Artikel	Endrohre	Durchmesser	Bestellnummer	MSRP
Item	Tip design	Tip dimension	Part number	
ESD / RM	OO	2x Ø 70 mm	B5319.00700	\$ 981.03
ESD / RM	OO	2x Ø 76 mm+	B5319.00760	\$ 1,013.15
ESD / RM	OO	2x Ø 83 mm+	B5319.00831	\$ 1,111.33
ESD / RM	OO OO	4x Ø 70*mm+	B5319.02320	\$ 1,552.98
ESD / RM		1x 160x80 mm ^{oo+}	B5319.02250	\$ 1,111.33
ESD / RM		2x 160x80*mm ^{oo+}	B5319.02260	\$ 1,659.19

BMW E46

318ci Cabrio (105 kW)[N42][N46]

Artikel	Endrohre	Durchmesser	Bestellnummer	MSRP
Item	Tip design	Tip dimension	Part number	
ESD / RM	OO	2x Ø 70 mm	B5320.00700	\$ 981.03
ESD / RM	OO	2x Ø 76 mm+	B5320.00760	\$ 1,013.15
ESD / RM	OO	2x Ø 83 mm+	B5320.00831	\$ 1,111.33
ESD / RM		1x 160x80 mm ^{°+}	B5320.02250	\$ 1,111.33



BMW E46

323ci Cabrio (120 kW+125 kW) 04/2000 - 06/2000

Artikel	Endrohre	Durchmesser	Bestellnummer	MSRP
Item	Tip design	Tip dimension	Part number	
ESD / RM	OO	2x Ø 70 mm	B5303.00700	\$ 896.94
ESD / RM	OO	2x Ø 76 mm+	B5303.00760	\$ 989.06
ESD / RM	OO	2x Ø 83 mm+	B5303.00831	\$ 1,037.24
ESD / RM		1x 160x80 mm ^{°+}	B5303.02250	\$ 1,037.24

BMW E46

320i/ci (125 kW)[M54] ♦ 325i/ci (141 kW)[M54] ♦ 330i/ci (170 kW)[M54]

Artikel	Endrohre	Durchmesser	Bestellnummer	MSRP
Item	Tip design	Tip dimension	Part number	
SR (!) / SP (!)			B5008.00000	\$ 216.51
SR(!) ab Kat/ SP(!) Kat back			B5009.00000	\$ 495.44
ESD / RM	OO	2x Ø 70 mm	B5304.00700	\$ 1,029.21
ESD / RM	OO	2x Ø 76 mm+	B5304.00760	\$ 1,111.33
ESD / RM	OO	2x Ø 83 mm+	B5304.00831	\$ 1,159.51
ESD (10) / RM (10)	OO OO	4x Ø 70*mm+	B5304.02320	\$ 1,651.16
ESD / RM		1x 160x80 mm ^{°+}	B5304.02250	\$ 1,159.51
ESD (10)/ RM (10)	 	2x 160x80*mm ^{°+}	B5304.02260	\$ 1,707.37



BMW E46

M3 3,2i (252 kW)

Artikel	Endrohre	Durchmesser	Bestellnummer	MSRP
Item	Tip design	Tip dimension	Part number	
MSD (!) / IM (!)			B5313.00000	\$ 688.16
ESD / RM	OO OO	4x Ø 76*mm [°]	B5313.00760	\$ 1,859.94
ESD / RM	OO OO	4x Ø 83*mm [°]	B5313.00831	\$ 2,080.54
ESD(7,12)/RM(7,12)	OO OO	4x Ø 83*mm [°]	B5313.00832	\$ 2,467.80



BMW E46

318d/cd (85 kW)[M47][M47N] ♦ 320d/cd (100 kW+110 kW)[M47][M47N]

Artikel	Endrohre	Durchmesser	Bestellnummer	MSRP
Item	Tip design	Tip dimension	Part number	
ESD / RM	OO	2x Ø 70 mm	B5247.00700	\$ 1,021.18
ESD / RM	OO	2x Ø 76 mm+	B5247.00760	\$ 1,103.30
ESD / RM	OO	2x Ø 83 mm+	B5247.00831	\$ 1,151.48
ESD / RM	OO OO	4x Ø 70*mm+	B5247.02320	\$ 1,593.13
ESD / RM		1x 160x80 mm ^{°+}	B5247.02250	\$ 1,151.48
ESD / RM	 	2x 160x80* mm ^{°+}	B5247.02260	\$ 1,699.34

BMW E46

330d/cd (135 kW+150 kW)[M57][M57N]

Artikel	Endrohre	Durchmesser	Bestellnummer	MSRP
Item	Tip design	Tip dimension	Part number	
ESD / RM	OO	2x Ø 70 mm	B5302.00700	\$ 1,119.36
ESD / RM	OO	2x Ø 76 mm+	B5302.00760	\$ 1,151.48
ESD / RM	OO	2x Ø 83 mm+	B5302.00831	\$ 1,199.66
ESD / RM	OO OO	4x Ø 70*mm+	B5302.02320	\$ 1,691.31
ESD / RM		1x 160x80 mm ^{°°} +	B5302.02250	\$ 1,199.66
ESD / RM		2x 160x80* mm ^{°°} +	B5302.02260	\$ 1,747.52

BMW E46 Compact

316i (85 kW) ♦ 318i (105 kW) ♦ 325i (141 kW)

Artikel	Endrohre	Durchmesser	Bestellnummer	MSRP
Item	Tip design	Tip dimension	Part number	
ESD / RM	OO	2x Ø 70* mm+	B5315.00700	\$ 1,175.57
ESD / RM	OO OO	4x Ø 70* mm+	B5315.02320	\$ 1,552.98

BMW E46 Compact

318td (85 kW) ♦ 320td (110 kW)

Artikel	Endrohre	Durchmesser	Bestellnummer	MSRP
Item	Tip design	Tip dimension	Part number	
ESD / RM	OO	2x Ø 70* mm+	B5322.00700	\$ 1,143.45
ESD / RM	OO OO	4x Ø 70* mm+	B5322.02320	\$ 1,520.86

BMW E90 Limousine ♦ BMW E91 Touring

316i (85 kW) ♦ 318i (95 kW) ♦ 320i (110 kW)

Artikel	Endrohre	Durchmesser	Bestellnummer	MSRP
Item	Tip design	Tip dimension	Part number	
ESD / RM	OO	2x Ø 70 mm+	B5327.00700	\$ 1,175.57
ESD / RM	OO	2x Ø 76 mm+	B5327.00760	\$ 1,207.69
ESD / RM	OO OO	4x Ø 70* mm+	B5327.02320	\$ 1,739.49

BMW E90 Limousine ♦ BMW E91 Touring

325i/xi (155 kW/160 kW)

Artikel	Endrohre	Durchmesser	Bestellnummer	MSRP
Item	Tip design	Tip dimension	Part number	
MSD / IM			B5339.00001	\$ 1,029.21
ESD / RM	OO	2x Ø 70 mm+	B5339.00702	\$ 1,215.72
ESD / RM	OO	2x Ø 76 mm+	B5339.00762	\$ 1,247.84
ESD / RM	OO OO	4x Ø 70* mm+	B5339.00764	\$ 1,859.94

BMW E90 Limousine ♦ BMW E91 Touring

330i/xi (190 kW)

Artikel	Endrohre	Durchmesser	Bestellnummer	MSRP
Item	Tip design	Tip dimension	Part number	
MSD / IM			B5325.00001	\$ 1,029.21
ESD / RM	OO	2x Ø 70 mm+	B5325.00700	\$ 1,247.84
ESD / RM	OO	2x Ø 76 mm+	B5325.00760	\$ 1,279.96
ESD / RM	OO OO	4x Ø 70* mm+	B5325.02320	\$ 1,952.06

**BMW E90 Limousine ♦ BMW E91 Touring
335i (225 kW)**

Artikel	Endrohre	Durchmesser	Bestellnummer	MSRP
Item	Tip design	Tip dimension	Part number	
ESD / RM	O O	2x Ø 90 mm ^{oo}	B5332.00903	\$ 2,307.20
ESD / RM	O O	2x Ø 102 mm	B5332.01023	\$ 2,467.80
ESD / RM	OO OO	4x Ø 76* mm+	B5332.00764	\$ 2,628.40

**BMW E90 Limousine ♦ BMW E91 Touring
318d (89 kW/90 kW) ♦ 320d (110 kW/120 kW)**

Artikel	Endrohre	Durchmesser	Bestellnummer	MSRP
Item	Tip design	Tip dimension	Part number	
ESD / RM	OO	2x Ø 70 mm+	B5328.00700	\$ 1,159.51
ESD / RM	OO	2x Ø 76 mm+	B5328.00760	\$ 1,175.57
ESD / RM	OO OO	4x Ø 70* mm+	B5328.02320	\$ 1,747.52

**BMW E90 Limousine ♦ BMW E91 Touring
325d (145 kW) ♦ 330d/xd (170 kW)**

Artikel	Endrohre	Durchmesser	Bestellnummer	MSRP
Item	Tip design	Tip dimension	Part number	
ESD / RM	OO	2x Ø 70 mm+	B5330.00702	\$ 1,183.60
ESD / RM	OO	2x Ø 76 mm+	B5330.00762	\$ 1,215.72
ESD / RM	OO OO	4x Ø 70* mm+	B5330.00764	\$ 1,827.82

**BMW E90 Limousine ♦ BMW E91 Touring
335d (210 kW)**

Artikel	Endrohre	Durchmesser	Bestellnummer	MSRP
Item	Tip design	Tip dimension	Part number	
ESD / RM	O O	2x Ø 90 mm	B5335.00903	\$ 2,307.20
ESD / RM	O O	2x Ø 102 mm	B5335.01023	\$ 2,467.80
ESD / RM	OO OO	4x Ø 76* mm+	B5335.00764	\$ 2,628.40

**BMW E92 Coupe ♦ BMW E93 Cabrio
320i (125 kW)**

Artikel	Endrohre	Durchmesser	Bestellnummer	MSRP
Item	Tip design	Tip dimension	Part number	
ESD / RM	OO	2x Ø 70 mm+	B5333.00702	\$ 1,191.63
ESD / RM	OO	2x Ø 76 mm+	B5333.00762	\$ 1,223.75
ESD / RM	OO OO	4x Ø 70* mm+	B5333.00704	\$ 1,755.55

**BMW E92 Coupe ♦ BMW E93 Cabrio
325i (160 kW)**

Artikel	Endrohre	Durchmesser	Bestellnummer	MSRP
Item	Tip design	Tip dimension	Part number	
ESD / RM	OO	2x Ø 70 mm+	B5334.00702	\$ 1,231.78
ESD / RM	OO	2x Ø 76 mm+	B5334.00762	\$ 1,263.90
ESD / RM	OO OO	4x Ø 70* mm+	B5334.00704	\$ 1,936.00

BMW E92 Coupe ♦ BMW E93 Cabrio
330i/xi (200 kW)

Artikel	Endrohre	Durchmesser	Bestellnummer	MSRP
Item	Tip design	Tip dimension	Part number	
MSD / IM			B5325.00001	\$ 1,029.21
ESD / RM	OO	2x Ø 70 mm+	B5340.00702	\$ 1,263.90
ESD / RM	OO	2x Ø 76 mm+	B5340.00762	\$ 1,296.02
ESD / RM	OO OO	4x Ø 70* mm+	B5340.00704	\$ 1,968.12

BMW E92 Coupe ♦ BMW E93 Cabrio
335i (225 kW)

Artikel	Endrohre	Durchmesser	Bestellnummer	MSRP
Item	Tip design	Tip dimension	Part number	
ESD / RM	O O	2x Ø 90 mm ^{oo}	B5331.00903	\$ 2,307.20
ESD / RM	O O	2x Ø 102 mm	B5331.01023	\$ 2,467.80
ESD / RM	OO OO	4x Ø 76* mm+	B5331.00764	\$ 2,628.40

BMW E92 Coupe
320d (130 kW)

Artikel	Endrohre	Durchmesser	Bestellnummer	MSRP
Item	Tip design	Tip dimension	Part number	
ESD / RM	OO	2x Ø 70 mm+	B5336.00702	\$ 1,175.57
ESD / RM	OO	2x Ø 76 mm+	B5336.00762	\$ 1,191.63
ESD / RM	OO OO	4x Ø 70* mm+	B5336.00704	\$ 1,763.58

BMW E92 Coupe ♦ BMW E93 Cabrio
325d (145 kW) ♦ 330d (170 kW)

Artikel	Endrohre	Durchmesser	Bestellnummer	MSRP
Item	Tip design	Tip dimension	Part number	
ESD / RM	OO	2x Ø 70 mm+	B5337.00702	\$ 1,199.66
ESD / RM	OO	2x Ø 76 mm+	B5337.00762	\$ 1,231.78
ESD / RM	OO OO	4x Ø 70* mm+	B5337.00704	\$ 1,843.88

BMW E92 Coupe ♦ BMW E93 Cabrio
335d (210 kW)

Artikel	Endrohre	Durchmesser	Bestellnummer	MSRP
Item	Tip design	Tip dimension	Part number	
ESD / RM	O O	2x Ø 90 mm ^{oo}	B5338.00903	\$ 2,307.20
ESD / RM	O O	2x Ø 102 mm	B5338.01023	\$ 2,467.80
ESD / RM	OO OO	4x Ø 76* mm+	B5338.00764	\$ 2,628.40

BMW E92 Coupe
M3 (309 kW)

Artikel	Endrohre	Durchmesser	Bestellnummer	MSRP
Item	Tip design	Tip dimension	Part number	
ESD / RM	OO OO	4x Ø 83*mm ^o	B5267.00835	\$ 2,839.00

BMW E34
520i (95 kW)

Artikel	Endrohre	Durchmesser	Bestellnummer	MSRP
Item	Tip design	Tip dimension	Part number	
ESD / RM	OO	2x Ø 70 mm	B5225.00700	\$ 1,029.21

**BMW E34
520iS (110 kW)**

Artikel	Endrohre	Durchmesser	Bestellnummer	MSRP
Item	Tip design	Tip dimension	Part number	
ESD / RM	OO	2x Ø 70 mm	B5226.00700	\$ 1,029.21

**BMW E34
525i (125 kW)**

Artikel	Endrohre	Durchmesser	Bestellnummer	MSRP
Item	Tip design	Tip dimension	Part number	
ESD / RM	OO	2x Ø 70 mm	B5227.00700	\$ 1,167.54

**BMW E34
525iS (141 kW)**

Artikel	Endrohre	Durchmesser	Bestellnummer	MSRP
Item	Tip design	Tip dimension	Part number	
ESD / RM	OO	2x Ø 70 mm	B5228.00700	\$ 1,167.54

**BMW E34
530i (138 kW) ♦ 535i (155 kW)**

Artikel	Endrohre	Durchmesser	Bestellnummer	MSRP
Item	Tip design	Tip dimension	Part number	
ESD / RM	OO	2x Ø 70 mm	B5229.00700	\$ 1,215.72

**BMW E34
530i (160 kW)**

Artikel	Endrohre	Durchmesser	Bestellnummer	MSRP
Item	Tip design	Tip dimension	Part number	
ESD / RM	OO	2x Ø 70 mm	B5230.00700	\$ 1,223.75

**BMW E34
540i (210 kW)**

Artikel	Endrohre	Durchmesser	Bestellnummer	MSRP
Item	Tip design	Tip dimension	Part number	
ESD / RM	OO	2x Ø 70 mm	B5218.00700	\$ 1,223.75

**BMW E34
M5 3,6l (232 kW) ♦ M5 3,8l (250 kW)**

Artikel	Endrohre	Durchmesser	Bestellnummer	MSRP
Item	Tip design	Tip dimension	Part number	
ESD / RM	OO	2x Ø 83 mm+	B5231.00831	\$ 1,352.23

**BMW E39 Limousine mit Serienheckschürze/Serial Valance
520i (110 kW+125 kW) ♦ 523i (125 kW) ♦ 525i (141 kW) ♦ 528i (142 kW) ♦ 530i (170 kW)**

Artikel	Endrohre	Durchmesser	Bestellnummer	MSRP
Item	Tip design	Tip dimension	Part number	
ESD / RM	OO	2x Ø 76 mm+	B5232.00760	\$ 1,175.57
ESD / RM	OO	2x Ø 83 mm+	B5232.00831	\$ 1,223.75
ESD / RM	OO OO	4x Ø 76*mm+	B5232.02320	\$ 1,795.70

BMW E39 Limousine mit M-Technik-Serienheckschürze/M-Technik Valance
520i (110 kW+125 kW) ♦ 523i (125 kW) ♦ 525i (141 kW) ♦ 528i (142 kW) ♦ 530i (170 kW)

Artikel	Endrohre	Durchmesser	Bestellnummer	MSRP
Item	Tip design	Tip dimension	Part number	
ESD / RM	OO	2x Ø 76 mm+	B5232.09760	\$ 1,207.69
ESD / RM	OO	2x Ø 83 mm+	B5232.09831	\$ 1,255.87
ESD / RM	OO OO	4x Ø 76*mm+	B5232.02420	\$ 2,226.90

BMW E39 Limousine mit Serienheckschürze/Serial Valance
535i (173 kW) ♦ 540i (210 kW)

Artikel	Endrohre	Durchmesser	Bestellnummer	MSRP
Item	Tip design	Tip dimension	Part number	
ESD / RM	OO	2x Ø 76 mm+	B5233.00760	\$ 1,215.72
ESD / RM	OO	2x Ø 83 mm+	B5233.00831	\$ 1,263.90
ESD / RM	OO OO	4x Ø 76*mm+	B5233.02320	\$ 1,835.85

BMW E39 Limousine mit M-Technik-Serienheckschürze/M-Technik Valance
535i (173 kW) ♦ 540i (210 kW)

Artikel	Endrohre	Durchmesser	Bestellnummer	MSRP
Item	Tip design	Tip dimension	Part number	
ESD / RM	OO	2x Ø 76 mm+	B5233.09760	\$ 1,247.84
ESD / RM	OO	2x Ø 83 mm+	B5233.09831	\$ 1,296.02
ESD / RM	OO OO	4x Ø 76*mm+	B5233.02420	\$ 2,267.05

BMW E39 Limousine
M5 (295 kW)

Artikel	Endrohre	Durchmesser	Bestellnummer	MSRP
Item	Tip design	Tip dimension	Part number	
ESD (4) / RM (4)	OO OO	4x Ø 76 mm	B5248.00760	\$ 2,307.20
ESD (4) / RM (4)	OO OO	4x Ø 83 mm+	B5248.00831	\$ 2,403.56

BMW E39 Limousine mit Serienheckschürze/Serial Valance
525d (105 kW+120 kW) ♦ 530d (135 kW+142 kW)

Artikel	Endrohre	Durchmesser	Bestellnummer	MSRP
Item	Tip design	Tip dimension	Part number	
ESD / RM	OO	2x Ø 76 mm+	B5301.00760	\$ 1,344.20
ESD / RM	OO	2x Ø 83 mm+	B5301.00831	\$ 1,392.38

BMW E39 Limousine mit M-Technik-Serienheckschürze/M-Technik Valance
525d (105 kW+120 kW) ♦ 530d (135 kW+142 kW)

Artikel	Endrohre	Durchmesser	Bestellnummer	MSRP
Item	Tip design	Tip dimension	Part number	
ESD / RM	OO	2x Ø 76 mm+	B5301.09760	\$ 1,376.32
ESD / RM	OO	2x Ø 83 mm+	B5301.09831	\$ 1,424.50

BMW E39 Touring mit Serienheckschürze/Serial Valance
528i (142 kW) -->09/1998

Artikel	Endrohre	Durchmesser	Bestellnummer	MSRP
Item	Tip design	Tip dimension	Part number	
ESD / RM	OO	2x Ø 76 mm+	B5245.00760	\$ 1,175.57
ESD / RM	OO	2x Ø 83 mm+	B5245.00831	\$ 1,223.75

BMW E39 Touring mit M-Technik-Serienheckschürze/M-Technik Valance
528i (142 kW) -->09/1998

Artikel	Endrohre	Durchmesser	Bestellnummer	MSRP
Item	Tip design	Tip dimension	Part number	
ESD / RM	OO	2x Ø 76 mm+	B5245.09760	\$ 1,207.69
ESD / RM	OO	2x Ø 83 mm+	B5245.09831	\$ 1,255.87

BMW E39 Touring mit Serienheckschürze/Serial Valance
520i (110 kW+125 kW) ♦ 523i (125 kW) ♦ 525i (141 kW) ♦ 528i (142 kW) 09/1998--> ♦ 530i (170

Artikel	Endrohre	Durchmesser	Bestellnummer	MSRP
Item	Tip design	Tip dimension	Part number	
ESD / RM	OO	2x Ø 76 mm+	B5253.00760	\$ 1,175.57
ESD / RM	OO	2x Ø 83 mm+	B5253.00831	\$ 1,223.75

BMW E39 Touring mit M-Technik-Serienheckschürze/M-Technik Valance
520i (110 kW+125 kW) ♦ 523i (125 kW) ♦ 525i (141 kW) ♦ 528i (142 kW) 09/1998--> ♦ 530i (170

Artikel	Endrohre	Durchmesser	Bestellnummer	MSRP
Item	Tip design	Tip dimension	Part number	
ESD / RM	OO	2x Ø 76 mm+	B5253.09760	\$ 1,207.69
ESD / RM	OO	2x Ø 83 mm+	B5253.09831	\$ 1,255.87

BMW E39 Touring mit Serienheckschürze/Serial Valance
540i (210 kW)

Artikel	Endrohre	Durchmesser	Bestellnummer	MSRP
Item	Tip design	Tip dimension	Part number	
ESD / RM	OO	2x Ø 76 mm+	B5244.00760	\$ 1,215.72
ESD / RM	OO	2x Ø 83 mm+	B5244.00831	\$ 1,263.90

BMW E39 Touring mit M-Technik-Serienheckschürze/M-Technik Valance
540i (210 kW)

Artikel	Endrohre	Durchmesser	Bestellnummer	MSRP
Item	Tip design	Tip dimension	Part number	
ESD / RM	OO	2x Ø 76 mm+	B5244.09760	\$ 1,247.84
ESD / RM	OO	2x Ø 83 mm+	B5244.09831	\$ 1,296.02

BMW E39 Touring mit Serienheckschürze/Serial Valance
525d (105 kW+120 kW) ♦ 530d (135 kW+142 kW)

Artikel	Endrohre	Durchmesser	Bestellnummer	MSRP
Item	Tip design	Tip dimension	Part number	
ESD / RM	OO	2x Ø 76 mm+	B5300.00760	\$ 1,344.20
ESD / RM	OO	2x Ø 83 mm+	B5300.00831	\$ 1,392.38

BMW E39 Touring mit M-Technik-Serienheckschürze/M-Technik Valance
525d (105 kW+120 kW) ♦ 530d (135 kW+142 kW)

Artikel	Endrohre	Durchmesser	Bestellnummer	MSRP
Item	Tip design	Tip dimension	Part number	
ESD / RM	OO	2x Ø 76 mm+	B5300.09760	\$ 1,376.32
ESD / RM	OO	2x Ø 83 mm+	B5300.09831	\$ 1,424.50

BMW E60 Limousine ♦ BMW E61 Touring

520i (125 kW) ♦ 523i (130 kW+140 kW) ♦ 525i (141 kW+160 kW) ♦ 530i (170 kW+190 kW+200 kW)

Artikel	Endrohre	Durchmesser	Bestellnummer	MSRP
Item	Tip design	Tip dimension	Part number	
ESD / RM	OO	2x Ø 76 mm+	B5254.00760	\$ 1,239.81
ESD / RM	OO	2x Ø 83 mm+	B5254.00831	\$ 1,287.99
ESD / RM Limousine	OO OO	4x Ø 76*mm+	B5254.02320	\$ 2,275.08
ESD / RM Touring	OO OO	4x Ø 76*mm+	B5254.02420	

BMW E60 Limousine ♦ BMW E61 Touring

540i (225 kW) ♦ 545i (245 kW)

Artikel	Endrohre	Durchmesser	Bestellnummer	MSRP
Item	Tip design	Tip dimension	Part number	
ESD / RM	OO	2x Ø 76 mm+	B5256.00760	\$ 1,984.18
ESD / RM	OO	2x Ø 83 mm+	B5256.00831	\$ 2,032.36
ESD / RM Limousine	OO OO	4x Ø 76*mm+	B5256.02320	\$ 2,879.15
ESD / RM Touring	OO OO	4x Ø 76*mm+	B5256.02420	

BMW E60 Limousine ♦ BMW E61 Touring

550i (270 kW) ohne TÜV. Im Geltungsbereich der StVZO nicht zugelassen!

Artikel	Endrohre	Durchmesser	Bestellnummer	MSRP
Item	Tip design	Tip dimension	Part number	
ESD (!) / RM (!)	OO	2x Ø 76 mm+	B5250.00760	\$ 2,064.48
ESD (!) / RM (!)	OO	2x Ø 83 mm+	B5250.00831	\$ 2,128.72
ESD (!) / RM (!) Limousine	OO OO	4x Ø 76*mm+	B5250.02320	\$ 2,975.51
ESD (!) / RM (!) Touring	OO OO	4x Ø 76*mm+	B5250.02420	

BMW E60 Limousine

M5 (373 kW)

Artikel	Endrohre	Durchmesser	Bestellnummer	MSRP
Item	Tip design	Tip dimension	Part number	
ESD (4) / RM (4)	OO OO	4x Ø 83*mm	B5258.00831	\$ 3,079.90
ESD (4) / RM (4)	∞ ∞	4x 120x77 mm [∞]	B5258.02180	\$ 3,401.10

BMW E61 Touring

M5 (373 kW)

Artikel	Endrohre	Durchmesser	Bestellnummer	MSRP
Item	Tip design	Tip dimension	Part number	
ESD (4) / RM (4)	OO OO	4x Ø 83*mm	B5260.00831	\$ 3,079.90
ESD (4) / RM (4)	∞ ∞	4x 120x77 mm [∞]	B5260.02180	\$ 3,401.10

BMW E60 Limousine ♦ BMW E61 Touring

520d (120 kW) ♦ 525d (130 kW+144 kW) ♦ 530d (155 kW+160 kW+170 kW+173 kW)

Artikel	Endrohre	Durchmesser	Bestellnummer	MSRP
Item	Tip design	Tip dimension	Part number	
ESD / RM	OO	2x Ø 76 mm+	B5255.00760	\$ 1,440.56
ESD / RM	OO	2x Ø 83 mm+	B5255.00831	\$ 1,488.74
ESD / RM Limousine	OO OO	4x Ø 76*mm+	B5255.02320	\$ 2,459.77
ESD / RM Touring	OO OO	4x Ø 76*mm+	B5255.02420	

**BMW E60 Limousine ♦ BMW E61 Touring
535d (200 kW)**

Artikel	Endrohre	Durchmesser	Bestellnummer	MSRP
Item	Tip design	Tip dimension	Part number	
ESD / RM	OO	2x Ø 76 mm+	B5257.00760	\$ 1,851.91
ESD / RM	OO	2x Ø 83 mm+	B5257.00831	\$ 1,976.15
ESD (8) / RM (8)	OO OO	4x Ø 76*mm+	B5257.02320	\$ 2,887.18

**BMW E60 Limousine ♦ BMW E61 Touring
535d (210 kW)**

Artikel	Endrohre	Durchmesser	Bestellnummer	MSRP
Item	Tip design	Tip dimension	Part number	
ESD / RM	OO	2x Ø 76 mm+	B5265.00760	
ESD / RM	OO	2x Ø 83 mm+	B5265.00831	
ESD (8) / RM (8)	OO OO	4x Ø 76*mm+	B5265.02320	

**BMW E63 Coupe ♦ BMW E64 Cabrio
630Ci (190 kW)**

Artikel	Endrohre	Durchmesser	Bestellnummer	MSRP
Item	Tip design	Tip dimension	Part number	
ESD / RM	OO OO	4x Ø 76 mm	B5344.00764	
ESD / RM	OO OO	4x Ø 83 mm+	B5344.00834	

**BMW E63 Coupe ♦ BMW E64 Cabrio
645Ci (245 kW)**

Artikel	Endrohre	Durchmesser	Bestellnummer	MSRP
Item	Tip design	Tip dimension	Part number	
ESD / RM	OO OO	4x Ø 76 mm	B5308.00760	\$ 2,347.35
ESD / RM	OO OO	4x Ø 83 mm+	B5308.00831	\$ 2,443.71

**BMW E63 Coupe ♦ BMW E64 Cabrio
650Ci (270 kW) ohne TÜV. Im Geltungsbereich der StVZO nicht zugelassen!**

Artikel	Endrohre	Durchmesser	Bestellnummer	MSRP
Item	Tip design	Tip dimension	Part number	
ESD (!) / RM (!)	OO OO	4x Ø 76 mm	B5329.00764	\$ 2,387.50
ESD (!) / RM (!)	OO OO	4x Ø 83 mm+	B5329.00834	\$ 2,462.98

**BMW E63 Coupe ♦ BMW E64 Cabrio
M6 (373 kW) ohne TÜV. Im Geltungsbereich der StVZO nicht zugelassen!**

Artikel	Endrohre	Durchmesser	Bestellnummer	MSRP
Item	Tip design	Tip dimension	Part number	
ESD (!) / RM (!)	OO OO	4x Ø 83 mm+	B5311.00831	\$ 2,548.10
ESD (!) / RM (!)	∞ ∞	4x 120x77 mm ^{oo}	B5311.02180	\$ 2,919.30

**BMW E32
730i (138 kW) ♦ 735i (155 kW)**

Artikel	Endrohre	Durchmesser	Bestellnummer	MSRP
Item	Tip design	Tip dimension	Part number	
ESD / RM	OO	2x Ø 70 mm	B5236.00700	\$ 1,183.60

BMW E32
730i (160 kW)

Artikel	Endrohre	Durchmesser	Bestellnummer	MSRP
Item	Tip design	Tip dimension	Part number	
ESD / RM	OO	2x Ø 70 mm	B5237.00700	\$ 1,183.60

BMW E32
740i (210 kW)

Artikel	Endrohre	Durchmesser	Bestellnummer	MSRP
Item	Tip design	Tip dimension	Part number	
ESD / RM	OO	2x Ø 70 mm	B5219.00700	\$ 1,183.60

BMW E32
750i (220 kW) ohne TÜV. Im Geltungsbereich der StVZO nicht zugelassen!

Artikel	Endrohre	Durchmesser	Bestellnummer	MSRP
Item	Tip design	Tip dimension	Part number	
ESD (!) / RM (!)	OO	2x Ø 70 mm	B5224.00700	\$ 1,263.90

BMW E38
730i (160 kW) ♦ 735i (173 kW) ♦ 740i (210 kW)

Artikel	Endrohre	Durchmesser	Bestellnummer	MSRP
Item	Tip design	Tip dimension	Part number	
ESD (4) / RM (4)	OO OO	4x Ø 83 mm+	B5238.00831	\$ 2,096.60

BMW E38
750i (240 kW)

Artikel	Endrohre	Durchmesser	Bestellnummer	MSRP
Item	Tip design	Tip dimension	Part number	
ESD (4) / RM (4)	OO OO	4x Ø 83 mm+	B5239.00831	\$ 2,096.60

BMW E31
850ci (220 kW)[M70]

Artikel	Endrohre	Durchmesser	Bestellnummer	MSRP
Item	Tip design	Tip dimension	Part number	
ESD (4) / RM (4)	OO OO	4x Ø 83 mm	B5240.00831	\$ 2,016.30

BMW E31
850ci (240 kW)[M73]

Artikel	Endrohre	Durchmesser	Bestellnummer	MSRP
Item	Tip design	Tip dimension	Part number	
ESD (4) / RM (4)	OO OO	4x Ø 83 mm	B5241.00831	\$ 2,016.30

BMW E36/7 ♦ BMW E36/8
Z3 1,8i (85 kW) ♦ Z3 1,9i (87 kW)

Artikel	Endrohre	Durchmesser	Bestellnummer	MSRP
Item	Tip design	Tip dimension	Part number	
ESD / RM	OO	2x Ø 76 mm+	B5213.00760	\$ 832.70
ESD / RM	OO OO	4x Ø 76 mm+	B5213.02420	\$ 1,464.65

BMW E36/7 ♦ BMW E36/8

Z3 2,0l (110 kW) -->09/99 ♦ Z3 2,8l (142 kW) -->09/99

Artikel	Endrohre	Durchmesser	Bestellnummer	MSRP
Item	Tip design	Tip dimension	Part number	
ESD / RM	OO	2x Ø 76 mm+	B5214.00760	\$ 997.09
ESD / RM	OO OO	4x Ø 76 mm+	B5214.02420	\$ 1,569.04

BMW E36/7 ♦ BMW E36/8

Z3 2,0l (110 kW) 10/99--> ♦ Z3 2,8l (142 kW) 10/99-->

Artikel	Endrohre	Durchmesser	Bestellnummer	MSRP
Item	Tip design	Tip dimension	Part number	
ESD / RM	OO	2x Ø 76 mm+	B5310.00760	\$ 997.09
ESD / RM	OO OO	4x Ø 76 mm+	B5310.02420	\$ 1,569.04

BMW E36/7 ♦ BMW E36/8

Z3 2,2l (125 kW) ♦ Z3 3,0l (170 kW)

Artikel	Endrohre	Durchmesser	Bestellnummer	MSRP
Item	Tip design	Tip dimension	Part number	
ESD / RM	OO	2x Ø 76 mm+	B5261.00760	\$ 1,167.54
ESD / RM	OO OO	4x Ø 76 mm+	B5261.02420	\$ 1,731.46

BMW E36/7S ♦ BMW E36/8S

Z3M 3,2l (236 kW+239 kW)

Artikel	Endrohre	Durchmesser	Bestellnummer	MSRP
Item	Tip design	Tip dimension	Part number	
ESD■(4) / RM■(4)	OO OO	4x Ø 76 mm	B5215.00760	\$ 1,859.94
ESD■(4) / RM■(4)	OO OO	4x Ø 83 mm+	B5215.00831	\$ 2,016.30

BMW E85 Roadster ♦ BMW E86 Coupe mit Serienheckschürze/Serial Valance

Z4 2,2l (125 kW) ♦ Z4 2,5l (141 kW) ♦ Z4 3,0l (170 kW)



Artikel	Endrohre	Durchmesser	Bestellnummer	MSRP
Item	Tip design	Tip dimension	Part number	
SR (!) / SP (!)			B5262.00000	\$ 200.45
ESD / RM		1 x 160x80mm ^{oo}	B5262.02310	\$ 1,392.38
ESD / RM	OO	2 x Ø 76 mm	B5262.00760	\$ 1,344.20
ESD / RM	OO OO	4 x Ø 76*mm+	B5262.02320	\$ 2,210.84
ESD / RM		2 x 160x80*mm+ ^{oo}	B5262.02240	\$ 2,307.20

BMW E85 Roadster ♦ BMW E86 Coupe mit Aerodynamic-Heckschürze/Aerodynamic Valance



Z4 2,2l (125 kW) ♦ Z4 2,5l (141 kW) ♦ Z4 3,0l (170 kW)

Artikel	Endrohre	Durchmesser	Bestellnummer	MSRP
Item	Tip design	Tip dimension	Part number	
SR (!) / SP (!)			B5262.00000	\$ 200.45
ESD / RM		1 x 160x80mm ^{oo}	B5262.02410	\$ 1,400.41
ESD / RM	OO	2 x Ø 76*mm+	B5262.09760	\$ 1,352.23
ESD / RM	OO OO	4 x Ø 76*mm+	B5262.02420	\$ 2,218.87
ESD / RM		2 x 160x80*mm+ ^{oo}	B5262.02250	\$ 2,315.23

BMW E85 Roadster ♦ BMW E86 Coupe mit Serienheckschürze/Serial Valance
Z4 2,5l (130 kW) ♦ Z4 2,5l Si (160 kW) ♦ Z4 3,0l Si (195 kW)

Artikel	Endrohre	Durchmesser	Bestellnummer	MSRP
Item	Tip design	Tip dimension	Part number	
ESD / RM		1 x 160x80mm ^{°°}	B5264.01600	\$ 1,392.38
ESD / RM	OO	2 x Ø 76 mm	B5264.00762	\$ 1,344.20
ESD / RM	OO OO	4 x Ø 76*mm+	B5264.00764	\$ 2,210.84
ESD / RM		2 x 160x80*mm ^{°°}	B5264.01602	\$ 2,307.20

BMW E85 Roadster ♦ BMW E86 Coupe mit Aerodynamic-Heckschürze/Aerodynamic Valance
Z4 2,5l (130 kW) ♦ Z4 2,5l Si (160 kW) ♦ Z4 3,0l Si (195 kW)

Artikel	Endrohre	Durchmesser	Bestellnummer	MSRP
Item	Tip design	Tip dimension	Part number	
ESD / RM		1 x 160x80mm ^{°°}	B5264.01690	\$ 1,400.41
ESD / RM	OO	2 x Ø 76 mm	B5264.09762	\$ 1,352.23
ESD / RM	OO OO	4 x Ø 76*mm+	B5264.09764	\$ 2,218.87
ESD / RM		2 x 160x80*mm ^{°°}	B5264.01692	\$ 2,315.23

BMW E85 Roadster ♦ BMW E86 Coupe
Z4M 3,2l (252 kW)

Artikel	Endrohre	Durchmesser	Bestellnummer	MSRP
Item	Tip design	Tip dimension	Part number	
ESD / RM	OO OO	4 x Ø 83*mm	B5263.00835	\$ 2,307.20
ESD / RM		2 x 160x80*mm ^{°°}	B5263.01602	\$ 2,467.80

BMW E52 Roadster
Z8 5,0l (295 kW)

Artikel	Endrohre	Durchmesser	Bestellnummer	MSRP
Item	Tip design	Tip dimension	Part number	
ESD (4) / RM (4)	-----	-----	B5312.00000	\$ 3,240.50

BMW E83
X3 3,0l (170 kW)

Artikel	Endrohre	Durchmesser	Bestellnummer	MSRP
Item	Tip design	Tip dimension	Part number	
ESD / RM	OO	2x Ø 76 mm	B5316.00760	\$ 1,151.48

BMW E83
X3 3,0d (150 kW)

Artikel	Endrohre	Durchmesser	Bestellnummer	MSRP
Item	Tip design	Tip dimension	Part number	
ESD / RM	OO	2x Ø 76 mm	B5317.00760	\$ 989.06

BMW E53
X5 3,0l (170 kW) ♦ X5 4,4l (210 kW)

Artikel	Endrohre	Durchmesser	Bestellnummer	MSRP
Item	Tip design	Tip dimension	Part number	
ESD (4) / RM (4)	OO OO	4x Ø 83 mm	B5307.00831	\$ 2,307.20
ESD (4) / RM (4)		2x 160x80 mm ^{°°}	B5307.02410	\$ 2,596.28

BMW E53

X5 4,6iS (255 kW)

Artikel	Endrohre	Durchmesser	Bestellnummer	MSRP
Item	Tip design	Tip dimension	Part number	
ESD (4) / RM (4)	OO OO	4x Ø 83 mm	B5318.00831	\$ 2,467.80
ESD (4) / RM (4)		2x 160x80 mm ^{°°}	B5318.02410	\$ 2,806.88

BMW E53

X5 3,0d (135 kW+160 kW)

Artikel	Endrohre	Durchmesser	Bestellnummer	MSRP
Item	Tip design	Tip dimension	Part number	
ESD (4) / RM (4)	OO OO	4x Ø 83 mm	B5321.00831	\$ 2,371.44
ESD (4) / RM (4)		2x 160x80 mm ^{°°}	B5321.02410	\$ 2,660.52

BMW E70

X5 3,0Si (200 kW)

Artikel	Endrohre	Durchmesser	Bestellnummer	MSRP
Item	Tip design	Tip dimension	Part number	
ESD / RM	OO OO	4x Ø 83* mm ^{°°}	B5346.00834	

BMW E70

X5 4,8l (261 kW)

Artikel	Endrohre	Durchmesser	Bestellnummer	MSRP
Item	Tip design	Tip dimension	Part number	
ESD / RM	OO OO	4x Ø 83* mm ^{°°}	B5345.00834	\$ 2,673.37
ESD / RM		2x120x77 mm	B5345.01202	\$ 2,291.14

BMW E70

X5 3,0d (173 kW)

Artikel	Endrohre	Durchmesser	Bestellnummer	MSRP
Item	Tip design	Tip dimension	Part number	
ESD / RM	OO OO	4x Ø 83* mm ^{°°}	B5347.00834	

BMW R50 ♦ BMW R52

Mini One (66 kW) ♦ Mini Cooper (85 kW)

Artikel	Endrohre	Durchmesser	Bestellnummer	MSRP
Item	Tip design	Tip dimension	Part number	
ESD / RM	OO	2x Ø 70 mm ^{°+}	B5400.00700	\$ 1,045.27
ESD / RM	O O	je 1x Ø 70 mm ^{°+}	B5400.00831	\$ 1,167.54
ESD / RM	O	1x Ø 83 mm	B5400.00830	\$ 768.46

BMW R50 ♦ BMW R52

Mini One Cabrio (66 kW) ♦ Mini Cooper Cabrio (85 kW)

Artikel	Endrohre	Durchmesser	Bestellnummer	MSRP
Item	Tip design	Tip dimension	Part number	
ESD / RM	OO	2x Ø 70 mm ^{°+}	B5404.00700	\$ 1,127.39
ESD / RM	O O	je 1x Ø 70 mm ^{°+}	B5404.00831	\$ 1,199.66
ESD / RM	O	1x Ø 83 mm	B5404.00830	\$ 800.58

BMW R53

Mini Cooper S (120 kW) -->12/2003

Artikel	Endrohre	Durchmesser	Bestellnummer	MSRP
Item	Tip design	Tip dimension	Part number	
MSD / IM			B5401.00001	\$ 848.76
ESD / RM	OO	2x Ø 76 mm°	B5401.00760	\$ 1,183.60

BMW R53

Mini Cooper S (120 kW) 01/2004-->

Artikel	Endrohre	Durchmesser	Bestellnummer	MSRP
Item	Tip design	Tip dimension	Part number	
MSD / IM			B5402.00001	\$ 848.76
ESD / RM	OO	2x Ø 76 mm°	B5402.00760	\$ 1,183.60

BMW R53

Mini Cooper S (125 kW) ♦ Mini Cooper S Cabrio (125 kW)

Artikel	Endrohre	Durchmesser	Bestellnummer	MSRP
Item	Tip design	Tip dimension	Part number	
MSD / IM			B5403.00001	\$ 848.76
ESD / RM	OO	2x Ø 76 mm°	B5403.00760	\$ 1,183.60

Audi Q7
4,2l (257 kW)

Artikel	Endrohre	Durchmesser	Bestellnummer	MSRP
Item	Tip design	Tip dimension	Part number	
ESD ohne Endrohre RM without tips			A1221.00000	\$ 1,408.44
Endrohrsatz für ESD Audi Q7 Tips for muffler Audi	○ ○	2x 120x77*mm+°°	90.200.070+90 .200.071	\$ 607.86
Endrohrsatz für ESD Audi Q7 Tips for muffler Audi	○○ ○○	4x 120x77*mm+°°	90.200.074+90 .200.075	\$ 1,199.66

AUDI TT Typ 8N

1,8T (110 kW)[AUMF] ♦ 1,8T (132 kW)[AJQF][AUQF][AJQQ][AUQQ][ARYQ]

Artikel	Endrohre	Durchmesser	Bestellnummer	MSRP
Item	Tip design	Tip dimension	Part Number	
MSD / IM			A1206.00000	\$ 431.20
ESD / RM	○	1x Ø 102 mm	A1206.01021	\$ 1,045.27
ESD / RM	○ ○	2x Ø 102 mm	A1206.02102	\$ 1,512.83

AUDI TT Quattro Typ 8N

1,8T (132 kW)[AJQF][AUQF][AJQQ][AUQQ][ARYQ] ♦ 1,8T (165 kW)[APXQ][BAMQ]

Artikel	Endrohre	Durchmesser	Bestellnummer	MSRP
Item	Tip design	Tip dimension	Part Number	
MSD / IM			A1207.00000	\$ 495.44
ESD / RM	○ ○	2x Ø 102 mm°	A1207.02102	\$ 1,352.23

AUDI TT Typ 8J
2,0TFSi (147 kW)

Artikel	Endrohre	Durchmesser	Bestellnummer	MSRP
Item	Tip design	Tip dimension	Part Number	
ESD / RM	○○	2x Ø 83*mm	A1225.00832	
ESD / RM	○○	2x 90x70*mm°°	A1225.00972	
ESD / RM	○○ ○○	4x Ø 83*mm+	A1225.00834	\$ 1,763.58
ESD / RM	○○ ○○	4x 90x70 mm°°+	A1225.00974	\$ 1,827.82

AUDI TT Quattro Typ 8J
3,2l (184 kW)

Artikel	Endrohre	Durchmesser	Bestellnummer	MSRP
Item	Tip design	Tip dimension	Part Number	
ESD / RM	○○ ○○	4x Ø 83*mm+	A1224.00834	\$ 1,763.58
ESD / RM	○○ ○○	4x 90x70 mm°°+	A1224.00974	\$ 1,827.82

AUDI A3 Typ 8L

1,6l (74 kW)[AEH][AKL] ♦ 1,6l (75 kW)[BFQ][AVU] ♦ 1,8l (92 kW)[AGN][APG] ♦ 1,8T (110 kW)[/

Artikel	Endrohre	Durchmesser	Bestellnummer	MSRP
Item	Tip design	Tip dimension	Part number	
MSD / IM			A1205.00000	\$ 431.20
ESD / RM	OO	2x Ø 70 mm	A1205.00700	\$ 776.49

AUDI S3 Quattro Typ 8L

1,8T (154 kW)[APY][AMK][AUL] ♦ 1,8T (165 kW)[BAM]

Artikel	Endrohre	Durchmesser	Bestellnummer	MSRP
Item	Tip design	Tip dimension	Part number	
MSD / IM			A1209.00000	\$ 479.38
ESD / RM	OO	2x Ø 70 mm°	A1209.00700	\$ 1,159.51

AUDI A3 Typ 8P

2,0TDi (103 kW)[BMM][BKD][AZV]

Artikel	Endrohre	Durchmesser	Bestellnummer	MSRP
Item	Tip design	Tip dimension	Part number	
MSD / IM			A1208.00001	\$ 656.04
ESD / RM	OO	2x Ø 76* mm°	A1208.00762	\$ 896.94
ESD / RM	OO	2x Ø 83* mm°+	A1208.00833	\$ 1,005.12
ESD / RM	OO OO	4x Ø 76* mm°+	A1208.00764	\$ 1,328.14
ESD / RM	OO OO	4x Ø 83* mm°+	A1208.00835	\$ 1,424.50

AUDI A4 Typ B5

1,6l (74 kW)[ADP][[ANA][ARM][ALZ][AHL] ♦ 1,8l (92 kW)[ADR][APT][ARG][AVV] ♦ 1,8T (110 kW)
2,4l (120 kW)[AJG][APZ][AMM] ♦ 2,4l (121 kW)[AGA][ALF][APS][ARJ][AML] ♦ 2,6l (110 kW)[ABC]
2,8l (142 kW)[ACK][ALG][APR][AQD][AMX]

Artikel	Endrohre	Durchmesser	Bestellnummer	MSRP
Item	Tip design	Tip dimension	Part number	
MSD / IM			A1101.00000	\$ 680.13
ESD / RM	OO	2x Ø 70 mm	A1203.00700	\$ 864.82

AUDI A4 Typ B5 Quattro

1,8T (110 kW)[B5LAEBQ1][B5AAEBQ1] ♦ 2,6l (110 kW)[B5LABCQ1][B5AABCQ1] ♦ 2,8l (128 kW)
2,8l (142 kW)[B5LACKQ1][B5AACKQ1]

Artikel	Endrohre	Durchmesser	Bestellnummer	MSRP
Item	Tip design	Tip dimension	Part number	
MSD / IM			A1102.00000	\$ 776.49
ESD / RM	OO	2x Ø 70 mm	A1204.00700	\$ 997.09

AUDI A4 Typ B5

S4 2,7l (195 kW)[B5LAGBQ1][B5AAGBQ1]

Artikel	Endrohre	Durchmesser	Bestellnummer	MSRP
Item	Tip design	Tip dimension	Part number	
ESD / RM	OO	2x Ø 70 mm	A1202.00700	\$ 1,103.30

AUDI A4 Typ B5

RS4 2,7l (280 kW)[ASJ][AZR]

Artikel	Endrohre	Durchmesser	Bestellnummer	MSRP
Item	Tip design	Tip dimension	Part number	
SR (!) / SP (!)			A1210.00000	\$ 272.72
ESD/RMΔ +MSD/IMΔ	OO	2x Ø 83 mm+	A1210.00831	\$ 2,628.40

AUDI A4 8H (Cabrio) Typ B6

1,8T (110 kW)[AVJ] ♦ 1,8T (120 kW)[BFB] ♦ 2,4l (120 kW)[AMM] ♦ 2,4l (125 kW)[BDV] ♦ 3,0l (162 kW)[BWA]

Artikel	Endrohre	Durchmesser	Bestellnummer	MSRP
Item	Tip design	Tip dimension	Part number	
ESD (4) / RM (4)	O O	2x Ø 90 mm°	A1212.00900	\$ 1,593.13
ESD (4) / RM (4)	OO OO	2x 120x77 mm°°+	A1212.02180	\$ 1,675.25

AUDI A4 8E (Limousine/Avant) Typ B6

1,8T (110 kW)[AVJ] ♦ 1,8T (120 kW)[BFB] ♦ 2,4l (120 kW)[AMM] ♦ 2,4l (125 kW)[BDV] ♦ 3,0l (162 kW)[BWA]

Artikel	Endrohre	Durchmesser	Bestellnummer	MSRP
Item	Tip design	Tip dimension	Part number	
ESD (4) / RM (4)	O O	2x Ø 90 mm°	A1214.00900	\$ 1,593.13
ESD (4) / RM (4)	OO OO	2x 120x77 mm°°+	A1214.02180	\$ 1,675.25

AUDI A4 8E (Limousine/Avant) Typ B6 Quattro

1,8T (110 kW)[AVJ] ♦ 1,8T (120 kW)[BFB] ♦ 2,4l (120 kW)[AMM] ♦ 2,4l (125 kW)[BDV] ♦ 3,0l (162 kW)[BWA]

Artikel	Endrohre	Durchmesser	Bestellnummer	MSRP
Item	Tip design	Tip dimension	Part number	
ESD (4) / RM (4)	O O	2x Ø 90 mm°	A1213.00900	\$ 1,651.16
ESD (4) / RM (4)	OO OO	2x 120x77 mm°°+	A1213.02180	\$ 1,683.28

AUDI S4 8E/8H (Limousine/Avant/Cabrio) Typ B6

4,2l (253 kW)[BBK]

Artikel	Endrohre	Durchmesser	Bestellnummer	MSRP
Item	Tip design	Tip dimension	Part Number	
ESD (4) / RM (4)	O O	2x Ø 90 mm°	A1215.00900	\$ 1,715.40
ESD (4) / RM (4)	OO OO	2x 120x77 mm°°+	A1215.02180	\$ 1,747.52

AUDI A4 8E (Limousine/Avant) Typ B7

2,0TDi (100 kW+103 kW)[BLB][BPN][BRE][BNA][BRC][BRF]

Artikel	Endrohre	Durchmesser	Bestellnummer	MSRP
Item	Tip design	Tip dimension	Part number	
ESD / RM	OO	2x Ø 76 mm°	A1219.00762	\$ 736.34
ESD (4) / RM (4)	OO OO	4x Ø 76 mm°	A1219.00764	\$ 1,651.16

AUDI A4 8E (Limousine/Avant) Typ B7

2,0TDi (125 kW)

Artikel	Endrohre	Durchmesser	Bestellnummer	MSRP
Item	Tip design	Tip dimension	Part number	
ESD / RM	OO	2x Ø 76 mm°	A1223.00762	\$ 736.34
ESD (4) / RM (4)	OO OO	4x Ø 76 mm°	A1223.00764	\$ 1,651.16

AUDI RS4 8E/8H (Limousine/Avant/Cabrio) Typ B7

4,2l (309 kW)

Artikel	Endrohre	Durchmesser	Bestellnummer	MSRP
Item	Tip design	Tip dimension	Part Number	
SR (!) / SP (!)			A1222.00000	\$ 399.08
ESD (4) / RM (4)	OO OO	4x Ø 83*mm ⁺	A1222.00834	\$ 3,079.90

AUDI S6 Typ 4B

4,2l (250 kW)[ANK]

Artikel	Endrohre	Durchmesser	Bestellnummer	MSRP
Item	Tip design	Tip dimension	Part Number	
ESD (4) / RM (4)	O O	2x Ø 90 mm [°]	A1217.00900	\$ 2,307.20
ESD (4) / RM (4)	OO OO	2x 120x77 mm ^{°+}	A1217.02180	\$ 2,339.32

AUDI RS6 Typ 4B

4,2l Biturbo (331 kW)[BCY]

Artikel	Endrohre	Durchmesser	Bestellnummer	MSRP
Item	Tip design	Tip dimension	Part Number	
ESD (4) / RM (4)	OO OO	2x 120x77 mm ^{°°}	A1216.02180	\$ 2,839.00

AUDI A6 Typ 4F

4,2l (246 kW)[BAT]

Artikel	Endrohre	Durchmesser	Bestellnummer	MSRP
Item	Tip design	Tip dimension	Part Number	
ESD (4) / RM (4)	OO OO	4x Ø 83*mm ⁺	A1218.00831	\$ 2,096.60
ESD (4) / RM (4)	OO OO	4x 90x70*mm ^{+°°}	A1218.02250	\$ 2,210.84

AUDI A6 Typ 4F

3,2l Fsi (188 kW)[AUK]

Artikel	Endrohre	Durchmesser	Bestellnummer	MSRP
Item	Tip design	Tip dimension	Part Number	
ESD (4) / RM (4)	OO OO	4x Ø 83*mm ⁺	A1220.00834	\$ 2,096.60
ESD (4) / RM (4)	OO OO	4x 90x70*mm ^{+°°}	A1220.00974	\$ 2,210.84

Mercedes – Benz W202

**C180 (90 kW) ♦ C200 (100 kW) ♦ C220 (110 kW) ♦ C230 (110 kW) ♦ C230K (142 kW+145 kW)
C280 (142 kW+ 145 kW)**

Artikel	Endrohre	Durchmesser	Bestellnummer	MSRP
Item	Tip design	Tip dimension	Part number	
ESD / RM	OO	2x Ø 83 mm ⁺	D7201.00831	\$ 1,021.18
ESD (7) / RM (7)	OO	2x 90x70 mm ^{+°°}	D7201.02240	\$ 1,103.30

Mercedes – Benz W203

C180 (95 kW) ♦ C200K (120 kW) ♦ C230K (145 kW)

Artikel	Endrohre	Durchmesser	Bestellnummer	MSRP
Item	Tip design	Tip dimension	Part number	
ESD / RM	OO	2x Ø 83 mm ⁺	D7238.00831	\$ 1,215.72
ESD (7) / RM (7)	OO	2x 90x70 mm ^{+°°}	D7238.02240	\$ 1,247.84

Mercedes – Benz W203

C240 (125 kW) ♦ C320 (160 kW)

Artikel	Endrohre	Durchmesser	Bestellnummer	MSRP
Item	Tip design	Tip dimension	Part number	
ESD / RM	OO	2x Ø 83 mm+	D7239.00831	\$ 1,239.81
ESD (7) / RM (7)	∞	2x 90x70 mm+°°	D7239.02240	\$ 1,271.93

Mercedes – Benz W203

C200CDi (85 kW) ♦ C220CDi (105 kW)

Artikel	Endrohre	Durchmesser	Bestellnummer	MSRP
Item	Tip design	Tip dimension	Part number	
ESD / RM	OO	2x Ø 83 mm+	D7240.00831	\$ 1,199.66
ESD (7) / RM (7)	∞	2x 90x70 mm+°°	D7240.02240	\$ 1,231.78

Mercedes – Benz CL203 Sportcoupe

C180 (95 kW) ♦ C200K (120 kW) ♦ C230K (145 kW)

Artikel	Endrohre	Durchmesser	Bestellnummer	MSRP
Item	Tip design	Tip dimension	Part number	
SR (!) / SP (!)			D7242.00000	\$ 144.24
ESD/MSDΔ / RM/IMΔ	OO	2x Ø 83 mm+	D7242.00831	\$ 1,263.90
ESD/MSDΔ(7)/RM/IMΔ(7)	∞	2x 90x70 mm+°°	D7242.02250	\$ 1,296.02

Mercedes – Benz W124 Limousine

500E (235 kW+240 kW)

Artikel	Endrohre	Durchmesser	Bestellnummer	MSRP
Item	Tip design	Tip dimension	Part number	
ESD / RM	OO	2x Ø 83 mm+	D7211.00831	\$ 1,859.94

Mercedes – Benz W210 Limousine

E200 (100 kW) ♦ E230 (110 kW) ♦ E240 (125 kW) ♦ E280 (142 kW)[R6] ♦ E320 (162 kW)[R6]

Artikel	Endrohre	Durchmesser	Bestellnummer	MSRP
Item	Tip design	Tip dimension	Part number	
ESD / RM	OO	2x Ø 83 mm+	D7221.00831	\$ 1,151.48
ESD (7) / RM (7)	∞	2x 90x70 mm+°°	D7221.02250	\$ 1,183.60

Mercedes – Benz W210 Limousine

E280 (150 kW)[V6] ♦ E320 (165 kW)[V6]

Artikel	Endrohre	Durchmesser	Bestellnummer	MSRP
Item	Tip design	Tip dimension	Part number	
ESD / RM	OO	2x Ø 83 mm+	D7213.00831	\$ 1,255.87
ESD (7) / RM (7)	∞	2x 90x70 mm+°°	D7213.02250	\$ 1,287.99

Mercedes – Benz W210 Limousine

E420 (205 kW)

Artikel	Endrohre	Durchmesser	Bestellnummer	MSRP
Item	Tip design	Tip dimension	Part number	
ESD / RM	OO	2x Ø 83 mm+	D7212.00831	\$ 1,287.99
ESD (7) / RM (7)	∞	2x 90x70 mm+°°	D7212.02250	\$ 1,320.11

Mercedes – Benz W210 Limousine

E430 (205 kW)

Artikel	Endrohre	Durchmesser	Bestellnummer	MSRP
Item	Tip design	Tip dimension	Part number	
ESD / RM	OO	2x Ø 83 mm+	D7227.00831	\$ 1,287.99
ESD (7) / RM (7)	OO	2x 90x70 mm+°°	D7227.02250	\$ 1,320.11

Mercedes – Benz W210 Limousine

E50 AMG (255 kW) ♦ E55AMG (255 kW) ohne TÜV. Im Geltungsbereich der StVZO nicht zuge

Artikel	Endrohre	Durchmesser	Bestellnummer	MSRP
Item	Tip design	Tip dimension	Part number	
ESD (!)	OO	2x Ø 102 mm+	D7215.01021	\$ 1,867.97
ESD (!)	OO	2x 90x70 mm+°°	D7215.02250	\$ 1,867.97

Mercedes – Benz W210 T-Modell

E200 (100 kW) ♦ E230 (110 kW) ♦ E240 (125 kW) ♦ E280 (142 kW+150 kW) ♦ E320 (162 kW+1

Artikel	Endrohre	Durchmesser	Bestellnummer	MSRP
Item	Tip design	Tip dimension	Part number	
ESD / RM	OO	2x Ø 83 mm+	D7214.00831	\$ 1,368.29

Mercedes – Benz W210 T-Model

E420 (205 kW) ♦ E430 (205 kW)

Artikel	Endrohre	Durchmesser	Bestellnummer	MSRP
Item	Tip design		Part number	
ESD / RM	OO	2x Ø 83 mm +	D7222.00831	\$ 1,408.44

Mercedes - Benz W140 Limousine ♦ Mercedes - Benz W140 Coupe

S/CL 400 SE/SEL/SEC (205 kW+210 kW) ♦ S/CL 420 SE/SEL/SEC (205 kW) ♦

S/CL 500 SE/SEL/SEC (235 kW+240 kW) ♦ S/CL 600 SE/SEL/SEC (290 kW)

Artikel	Endrohre	Durchmesser	Bestellnummer	MSRP
Item	Tip design	Tip dimension	Part number	
ESD / RM	OO	2x Ø 83 mm+	D7220.00831	\$ 1,328.14
ESD (7) / RM (7)	OO	2x 90x70 mm+°°	D7220.02250	\$ 1,360.26

Mercedes – Benz W220

S320 (165 kW) ♦ S430 (205 kW) ♦ S500 (225 kW) ♦ S600 (270 kW)

Artikel	Endrohre	Durchmesser	Bestellnummer	MSRP
Item	Tip design	Tip dimension	Part number	
MSD (4) / IM (4)			D7230.00000	\$ 981.03
ESD (4) / RM (4)	OO OO	4x 90x70 mm°°+	D7229.02240	\$ 2,080.54

Mercedes – Benz W215

CL500 (225 kW) ♦ CL600 (270 kW)

Artikel	Endrohre	Durchmesser	Bestellnummer	MSRP
Item	Tip design	Tip dimension	Part number	
MSD+ESDΔ(5)/IM+RMΔ(5)	OO OO	4x 90x70 mm°°+	D7237.02240	\$ 2,991.57

Mercedes – Benz W215

CL55AMG (368 kW) ohne TÜV. Im Geltungsbereich der StVZO nicht zugelassen!

Artikel	Endrohre	Durchmesser	Bestellnummer	MSRP
Item	Tip design	Tip dimension	Part number	
ESD (!)(4) / RM (!)(4)	OO OO	4x 120x77 mm°°+	D7236.02240	\$ 2,628.40

Mercedes – Benz W211 Limousine

E200K (120 kW) ♦ E240 (130 kW) ♦ E320 (165 kW) ♦ E500 (225 kW)

Artikel	Endrohre	Durchmesser	Bestellnummer	MSRP
Item	Tip design	Tip dimension	Part number	
ESD (4) / RM (4)	OO OO	4x Ø 83*mm [°] +	D7246.00831	\$ 2,387.50
ESD (4) / RM (4)	∞ ∞	4x 90x70*mm ^{°°}	D7246.02250	\$ 2,451.74

Mercedes – Benz W211 Limousine

E270CDI (130 kW) ♦ E320CDI (150 kW) ♦ E400CDI (191 kW)

Artikel	Endrohre	Durchmesser	Bestellnummer	MSRP
Item	Tip design	Tip dimension	Part number	
ESD (4) / RM (4)	OO OO	4x Ø 83*mm [°] +	D7254.00831	\$ 2,323.26
ESD (4) / RM (4)	∞ ∞	4x 90x70*mm ^{°°}	D7254.02250	\$ 2,387.50

Mercedes – Benz W211 Limousine

E55AMG (350 kW)

Artikel	Endrohre	Durchmesser	Bestellnummer	MSRP
Item	Tip design	Tip dimension	Part number	
ESD (4) / RM (4)	∞ ∞	4x 120x77*mm ^{°°}	D7253.02180	\$ 3,079.90

Mercedes – Benz W211 T-Modell

E200K (120 kW) ♦ E240 (130 kW) ♦ E320 (165 kW) ♦ E500 (225 kW)

Artikel	Endrohre	Durchmesser	Bestellnummer	MSRP
Item	Tip design	Tip dimension	Part number	
ESD (4) / RM (4)	OO OO	4x Ø 76*mm [°] +	D7259.00760	\$ 2,226.90

Mercedes – Benz W211 T-Modell

E270CDI (130 kW) ♦ E320CDI (150 kW) ♦ E400CDI (191 kW)

Artikel	Endrohre	Durchmesser	Bestellnummer	MSRP
Item	Tip design	Tip dimension	Part number	
ESD (4) / RM (4)	OO OO	4x Ø 76*mm [°] +	D7260.00760	\$ 2,112.66

Mercedes – Benz W211 T-Modell

E55AMG (350 kW)

Artikel	Endrohre	Durchmesser	Bestellnummer	MSRP
Item	Tip design	Tip dimension	Part number	
ESD (4) / RM (4)	∞ ∞	4x 120x77*mm ^{°°}	D7263.02180	\$ 3,079.90

Mercedes – Benz R170

SLK 200 (100 kW)

Artikel	Endrohre	Durchmesser	Bestellnummer	MSRP
Item	Tip design	Tip dimension	Part number	
ESD / RM	OO	2x Ø 83 mm+	D7203.00831	\$ 1,021.18
ESD (7) / RM (7)	∞	2x 90x70 mm ^{°°} +	D7203.02240	\$ 1,103.30

Mercedes – Benz R170

SLK 200K (120 kW)

Artikel	Endrohre	Durchmesser	Bestellnummer	MSRP
Item	Tip design	Tip dimension	Part number	
ESD / RM	OO	2x Ø 83 mm+	D7241.00831	\$ 1,021.18
ESD (7) / RM (7)	∞	2x 90x70 mm ^{°°} +	D7241.02240	\$ 1,103.30

**Mercedes – Benz R170
SLK 230K (142 kW)**

Artikel	Endrohre	Durchmesser	Bestellnummer	MSRP
Item	Tip design	Tip dimension	Part number	
AR / CP			D7001.00000	\$ 184.39
ESD / RM	OO	2x Ø 83 mm+	D7204.00831	\$ 1,111.33
ESD (7) / RM (7)	OO	2x 90x70 mm ^{oo+}	D7204.02240	\$ 1,143.45

**Mercedes – Benz R170
SLK 230K (145 kW)**

Artikel	Endrohre	Durchmesser	Bestellnummer	MSRP
Item	Tip design	Tip dimension	Part number	
ESD / RM	OO	2x Ø 83 mm+	D7234.00831	\$ 1,111.33
ESD (7) / RM (7)	OO	2x 90x70 mm ^{oo+}	D7234.02240	\$ 1,143.45

**Mercedes – Benz R170
SLK 320 (160 kW)**

Artikel	Endrohre	Durchmesser	Bestellnummer	MSRP
Item	Tip design	Tip dimension	Part number	
ESD / RM	OO	2x Ø 83 mm+	D7235.00831	\$ 1,151.48
ESD (7) / RM (7)	OO	2x 90x70 mm ^{oo+}	D7235.02240	\$ 1,183.60

**Mercedes – Benz R170
SLK 32AMG (260 kW) ohne TÜV. Im Geltungsbereich der StVZO nicht zugelassen!**

Artikel	Endrohre	Durchmesser	Bestellnummer	MSRP
Item	Tip design	Tip dimension	Part number	
ESD (!) / RM (!)	OO	2x Ø 83 mm+	D7233.00831	\$ 1,344.20
ESD (!) / RM (!)	OO	2x 90x70 mm ^{oo+}	D7233.02240	\$ 1,376.32

**Mercedes – Benz R171
SLK 200 (120 kW)**

Artikel	Endrohre	Durchmesser	Bestellnummer	MSRP
Item	Tip design	Tip dimension	Part number	
ESD (4) / RM (4)	OO OO	4x Ø 83 mm+	D7256.00831	\$ 2,096.60
ESD (4) / RM (4)	OO OO	4x 90x70 mm ^{oo+}	D7256.02240	\$ 2,307.20

**Mercedes – Benz R171
SLK 280 (170 kW)**

Artikel	Endrohre	Durchmesser	Bestellnummer	MSRP
Item	Tip design	Tip dimension	Part number	
ESD■(4)/RM■(4)	OO OO	4x Ø 83 mm+	D7262.00835	\$ 2,283.11
ESD■(4)/RM■(4)	OO OO	4x 90x70 mm ^{oo+}	D7262.00974	\$ 2,459.77

**Mercedes – Benz R171
SLK 350 (200 kW)**

Artikel	Endrohre	Durchmesser	Bestellnummer	MSRP
Item	Tip design	Tip dimension	Part number	
ESD■(4)/RM■(4)	OO OO	4x Ø 83 mm+	D7257.00831	\$ 2,283.11
ESD■(4)/RM■(4)	OO OO	4x 90x70 mm ^{oo+}	D7257.02240	\$ 2,459.77

Mercedes – Benz W208

CLK200 (100 kW) ♦ CLK200K (120 kW) ♦ CLK230K (142 kW+145 kW) ♦ CLK320 (160 kW)

Artikel	Endrohre	Durchmesser	Bestellnummer	MSRP
Item	Tip design	Tip dimension	Part number	
ESD / RM	OO	2x Ø 83 mm+	D7216.00831	\$ 1,021.18
ESD (7) / RM (7)	OO	2x 90x70 mm [°] +	D7216.02240	\$ 1,103.30

Mercedes – Benz W208

CLK430 (205 kW)

Artikel	Endrohre	Durchmesser	Bestellnummer	MSRP
Item	Tip design	Tip dimension	Part number	
ESD / RM	OO	2x Ø 83 mm+	D7223.00831	\$ 1,045.27
ESD (7) / RM (7)	OO	2x 90x70 mm [°] +	D7223.02240	\$ 1,127.39

Mercedes – Benz W208

CLK55AMG (255 kW) ohne TÜV. Im Geltungsbereich der StVZO nicht zugelassen!

Artikel	Endrohre	Durchmesser	Bestellnummer	MSRP
Item	Tip design	Tip dimension	Part number	
ESD (!) / RM (!)	OO	2x Ø 83 mm+	D7225.00831	\$ 1,247.84
ESD (!) / RM (!)	OO	2x 90x70 mm [°] +	D7225.02240	\$ 1,279.96

Mercedes – Benz W209 Coupe

CLK200K (120 kW) ♦ CLK240 (125 kW) ♦ CLK320 (160 kW) ♦ CLK500 (225 kW)

Artikel	Endrohre	Durchmesser	Bestellnummer	MSRP
Item	Tip design	Tip dimension	Part number	
ESD / RM	OO	2x Ø 83 mm+	D7248.00831	\$ 1,360.26
ESD / RM	OO	2x 90x70 mm [°] +	D7248.02240	\$ 1,392.38

Mercedes – Benz W209 Coupe

CLK55AMG (270 kW) -->05/2005 (- AMG Sportpaket) ohne TÜV. Im Geltungsbereich der StVZ

Artikel	Endrohre	Durchmesser	Bestellnummer	MSRP
Item	Tip design	Tip dimension	Part number	
ESD (!) / RM (!)	OO	2x 120x77* mm [°]	D7249.02180	\$ 1,585.10

Mercedes – Benz W209 Coupe

CLK55AMG (270 kW) 05/2005--> (+ AMG Sportpaket) ohne TÜV. Im Geltungsbereich der StV

Artikel	Endrohre	Durchmesser	Bestellnummer	MSRP
Item	Tip design	Tip dimension	Part number	
ESD (4) (!) / RM (4) (!)	OO OO	4x 120x77* mm [°]	D7250.02180	\$ 2,307.20

Mercedes – Benz W209 Cabrio

CLK320 (160 kW) ♦ CLK500 (225 kW)

Artikel	Endrohre	Durchmesser	Bestellnummer	MSRP
Item	Tip design	Tip dimension	Part number	
ESD / RM	OO	2x Ø 83 mm+	D7247.00831	\$ 1,360.26
ESD / RM	OO	2x 90x70 mm [°] +	D7247.02240	\$ 1,392.38

Mercedes – Benz W219

CLS500 (225 kW) ohne TÜV. Im Geltungsbereich der StVZO nicht zugelassen!

Artikel	Endrohre	Durchmesser	Bestellnummer	MSRP
Item	Tip design	Tip dimension	Part number	
ESD (4) (!) / RM (4) (!)	OO OO	4x Ø 90* mm [°] +	D7261.00900	\$ 2,676.58

Mercedes – Benz R129

280SL (142 kW) ♦ 300SL (140 kW+170 kW) ♦ 320SL (170 kW) ♦ 500SL (235 kW+240 kW) 198:

Artikel	Endrohre	Durchmesser	Bestellnummer	MSRP
Item	Tip design	Tip dimension	Part number	
ESD / RM	OO	2x Ø 83 mm+	D7218.00831	\$ 1,577.07
ESD / RM	OO	2x 90x70 mm [°] +	D7218.02240	\$ 1,691.31

Mercedes – Benz R129

SL280 (142 kW) ♦ SL320 (170 kW) ♦ SL500 (235 kW+240 kW) 10/1995 - 06/1998

Artikel	Endrohre	Durchmesser	Bestellnummer	MSRP
Item	Tip design	Tip dimension	Part number	
ESD / RM	OO	2x Ø 83 mm+	D7219.00831	\$ 1,787.67
ESD / RM	OO	2x 90x70 mm [°] +	D7219.02240	\$ 1,851.91

Mercedes – Benz R129

SL280 (142 kW+150 kW) ♦ SL320 (165 kW+170 kW) 07/1998-->

Artikel	Endrohre	Durchmesser	Bestellnummer	MSRP
Item	Tip design	Tip dimension	Part number	
ESD / RM	OO	2x Ø 83 mm+	D7228.00831	\$ 1,811.76

Mercedes – Benz R129

SL500 (225 kW+235 kW) 07/1998-->

Artikel	Endrohre	Durchmesser	Bestellnummer	MSRP
Item	Tip design	Tip dimension	Part number	
ESD / RM	OO	2x Ø 83 mm+	D7232.00831	\$ 1,811.76

Mercedes – Benz R230

SL350 (180 kW) ♦ SL500 (225 kW)

Artikel	Endrohre	Durchmesser	Bestellnummer	MSRP
Item	Tip design	Tip dimension	Part number	
MSD+ESDΔ(5,12)/RM+IMΔ	OO OO	4x Ø 76* mm [°]	D7243.00760	\$ 3,079.90
MSD+ESDΔ(5,12)/RM+IMΔ	OO OO	4x Ø 83* mm [°] +	D7243.00831	\$ 3,633.97

Mercedes – Benz R230

SL55AMG (350 kW+368 kW)

Artikel	Endrohre	Durchmesser	Bestellnummer	MSRP
Item	Tip design	Tip dimension	Part number	
MSD+ESDΔ(5)/RM+IMΔ(5)	OO OO	4x 120x77* mm [°]	D7252.02180	\$ 3,882.90

VW Golf 3 Limousine

1,6I (55 kW)[ABU] ♦ 1,8I (66 kW)[ABS][ADZ] ♦ 2,0I GTi (85 kW)[ADY][2E]

Artikel	Endrohre	Durchmesser	Bestellnummer	MSRP
Item	Tip design	Tip dimension	Part number	
ESD / RM	OO	2x Ø 83 mm	V2200.00831	\$ 768.46

VW Golf 3 Limousine

2,0I GTi 16V (110 kW)[ABF]

Artikel	Endrohre	Durchmesser	Bestellnummer	MSRP
Item	Tip design	Tip dimension	Part number	
ESD / RM	OO	2x Ø 83 mm	V2201.00831	\$ 776.49

VW Golf 3 Limousine
2,8l VR6 (128 kW)[AAA][AAH]

Artikel	Endrohre	Durchmesser	Bestellnummer	MSRP
Item	Tip design	Tip dimension	Part number	
ESD / RM	OO	2x Ø 83 mm	V2202.00831	\$ 776.49

VW Golf 4 Limousine
1,8l (92 kW)[AGN] ♦ 1,8T (110 kW)[AQA][AGU][AUM] ♦ 2,0l (85 kW)[APK][AQY] ♦ 2,3l (110 kW)[A

Artikel	Endrohre	Durchmesser	Bestellnummer	MSRP
Item	Tip design	Tip dimension	Part number	
MSD / IM			V2203.00000	\$ 431.20
ESD / RM	OO	2x Ø 70 mm	V2203.00700	\$ 776.49

VW Golf 4 Limousine
V6 4-Motion (150 kW)[AQP]

Artikel	Endrohre	Durchmesser	Bestellnummer	MSRP
Item	Tip design	Tip dimension	Part number	
MSD / IM			V2205.00000	\$ 479.38
ESD / RM	OO	2x Ø 70 mm°	V2205.00700	\$ 1,159.51

VW Golf 5 Limousine
GTi 2,0 FSI Turbo (147 kW)

Artikel	Endrohre	Durchmesser	Bestellnummer	MSRP
Item	Tip design	Tip dimension	Part number	
SR (!) / SP (!)			V2301.00000	
MSD / IM			V2300.00001	\$ 656.04
ESD / RM	OO	2x Ø 76* mm°	V2300.00762	\$ 896.94
ESD / RM	OO	2x Ø 83* mm°+	V2300.00833	\$ 1,005.12
ESD / RM	OO OO	4x Ø 76* mm°+	V2301.00764	\$ 1,328.14
ESD / RM	OO OO	4x Ø 83* mm°+	V2301.00835	\$ 1,424.50

VW Bora Limousine
1,8l (92 kW)[AGN] ♦ 1,8T (110 kW)[AQA][AGU][AUM] ♦ 2,0l (85 kW)[APK][AQY] ♦ 2,3l (110 kW)[A

Artikel	Endrohre	Durchmesser	Bestellnummer	MSRP
Item	Tip design	Tip dimension	Part number	
MSD / IM			V2206.00000	\$ 431.20
ESD / RM	OO	2x Ø 70 mm	V2206.00700	\$ 800.58

VW Bora Limousine
V6 4-Motion (150 kW)[AQP]

Artikel	Endrohre	Durchmesser	Bestellnummer	MSRP
Item	Tip design	Tip dimension	Part number	
MSD / IM			V2205.00000	\$ 479.38
ESD / RM	OO	2x Ø 70 mm°	V2205.00700	\$ 1,159.51

VW New Beetle
1,6l (75 kW)[AYD][BFS] ♦ 1,8l (85 kW)[AQY] ♦ 1,8T (110 kW)[AVC][AWU]

Artikel	Endrohre	Durchmesser	Bestellnummer	MSRP
Item	Tip design	Tip dimension	Part number	
MSD / IM			V2204.00000	\$ 431.20
ESD / RM	OO	2x Ø 70 mm	V2204.00700	\$ 776.49